

SPECIFICATIONS

1.General Specifications

Model	SZP-091U
Applicable Models	LR6-WJ / LR7-WJ•WT
Mounting Direction	Upright
Mounting Location	Indoor Only
Mass (Tolerance ±10%)	0.09kg
Outer Dimensions	Refer to the 2.Outer Dimensions
Remarks	There are no contents of controlled substances exceeding the threshold for the RoHS

2.Outer Dimensions

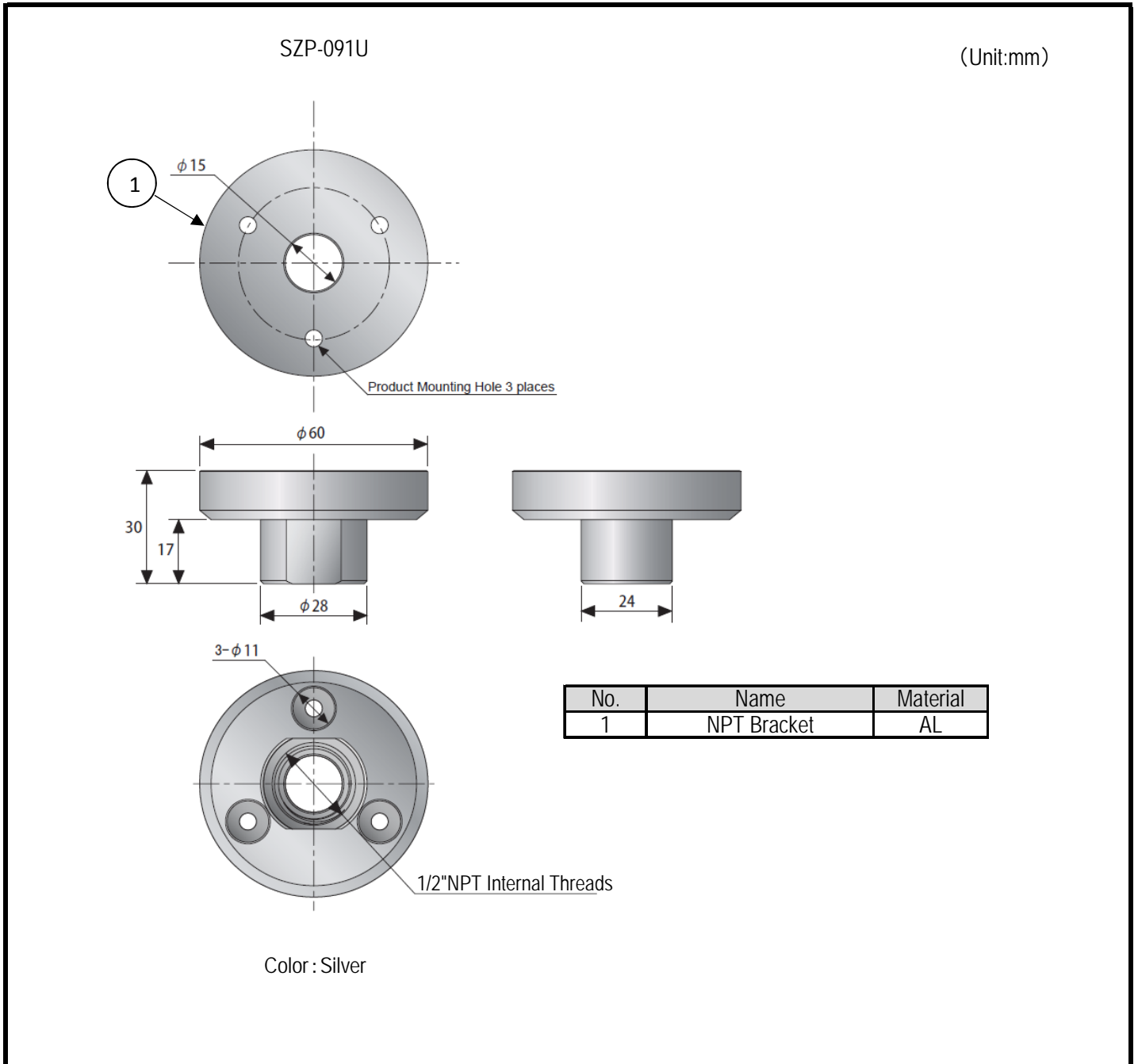

SZP-091-W18A-1_1

PATLITE Corporation